

1、产品概要 / Outline

- ◆ 铁氧体结构、低直流电阻
- ◆ 高能量储存、高品质因素
- ◆ 电感值范围较大
- ◆ 优异的端面强度和良好的焊锡性
- ◆ 工作温度：-40°C~+125°C
- ◆ 主要应用于医疗仪器、数字功放、笔记本电脑、网络通讯、电子产品等

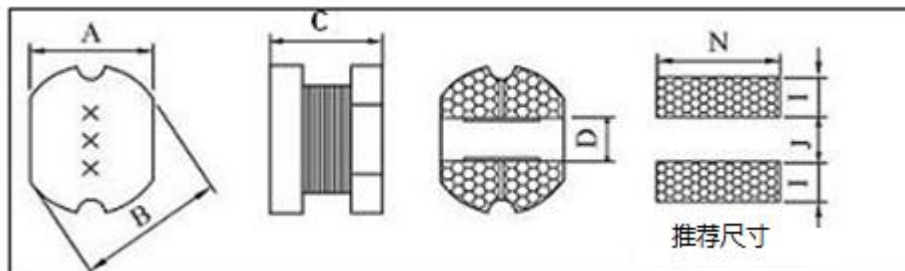

2、外观尺寸/ Appearance size 单位:mm



A±0.3	B±0.3	C±0.3	D	N	J	l
7.0	7.8	8.0	2.1	7.5	3.5	1.5

3、电气特性/Electrical characteristics

型号/NO	L/uH	DCR (Ω)	Isat(A)	Irms(A)
CD78-100K	10	0.039	6.00	7.50
CD78-150K	15	0.042	5.15	6.0
CD78-180K	18	0.05	4.50	5.5
CD78-220K	22	0.059	4.25	5.0
CD78-270K	27	0.071	4.00	4.5
CD78-330K	33	0.095	3.60	4.30
CD78-390K	39	0.090	3.10	3.68
CD78-470K	47	0.100	2.85	3.50
CD78-560K	56	0.134	2.00	3.0
CD78-680K	68	0.182	1.80	2.8
CD78-820K	82	0.201	1.68	2.5
CD78-101K	100	0.25	1.45	2.4
CD78-121K	120	0.263	1.31	1.80
CD78-151K	150	0.305	1.20	1.78
CD78-181K	180	0.353	1.00	1.75
CD78-221K	220	0.59	0.86	1.65
CD78-271K	270	0.750	0.70	1.45
CD78-331K	330	0.93	0.55	1.35
CD78-391K	390	1.120	0.40	1.2
CD78-471K	470	1.30	0.35	1.1

注释

- ◆ K 表示电感值的公差为±10%，M 表示电感值的公差为±20%
- ◆ K said inductance tolerance is ±10%, M said inductance tolerance is ± 20%
- ◆ 所有数据基于环境温度 25°C条件下测试
- ◆ All data is based on testing at an ambient temperature of 25 °C
- ◆ 测试条件：100KHz/0.25V
- ◆ 本页面未能录入全部或最新的数据，请您在订购前向本公司咨询精准参数及样品。
- ◆ We were unable to input all or the latest data on this page. Please consult our company for accurate parameters and samples before placing an order.

4 包装规格/ Packaging specifications 单位/mm

(1)、TAPE DIMENSIONS (unit: mm) & QUANTITIES (unit: PCS)

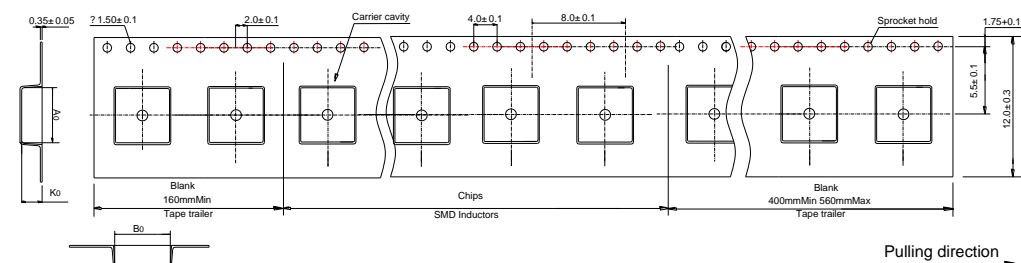

Type	Tape Dimensions			Reel	Quantities/Reel
	A ₀	B ₀	K ₀		
CD78	7.2	8.0	8.2	330*12	1000 PCS

(2)、DIMENSIONS OF REEL & TAPING FIGURES AND DRAWING DIRECTION

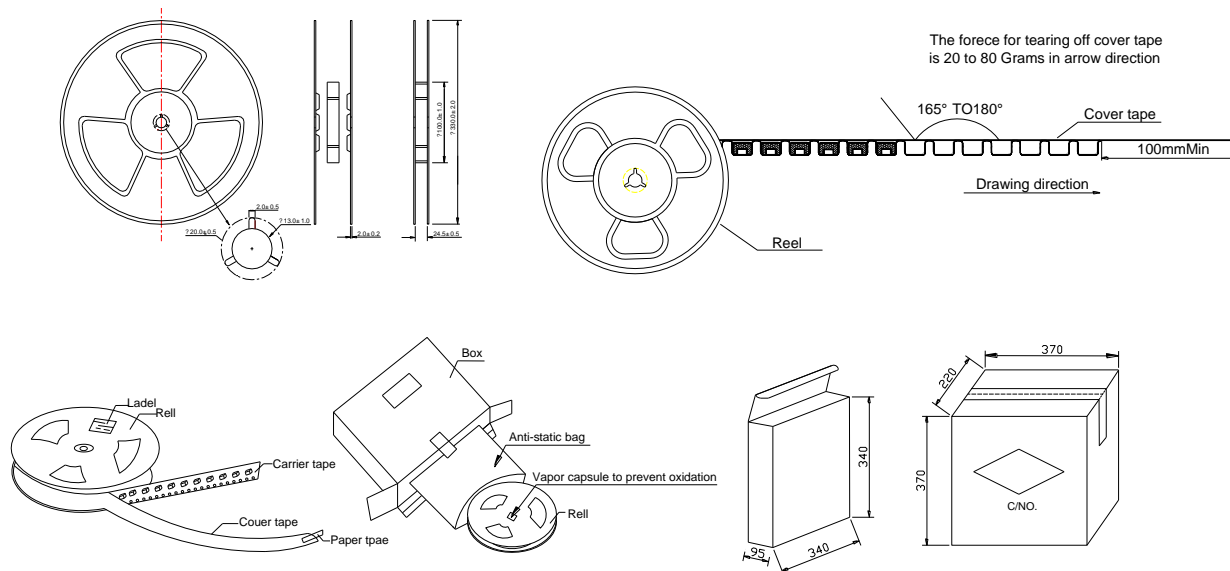

(3)、BOX AND CASE DIMENSIONS(UNIT:mm)&PACKAGING QUANTITIES(UNIT:PCS)

Type	Quantities(Unit:mm)	Quantities(Unit:m m)
	Inner Carton	Outer Carton
CD78	4/4000 PCS	4/16000PCS

5、焊接/welding

• 焊接原材料 Soldering Materials

(a) 焊料：推荐使用 96.5Sn/3.0Ag/0.5Cu 焊料，或者采用 Sn 含量不超过 97%的锡合金焊料。Solder: It is recommended to use 96.5Sn/3.0Ag/0.5Cu solder, or use Tin alloy solder with a Tin content not exceeding 97%.

(b) 助焊剂：推荐使用松香类助焊剂，请勿使用强酸性助焊剂（含氯量超过 0.2wt %），并且请勿使用水溶性助焊剂。Flux: It is recommended to use rosin-based flux. Acidic flux (with chlorine content exceeding 0.2wt %) and water-soluble flux are forbidden.

• 焊接温度及要求 Soldering Temperature & Requirements

(1) 回流焊 Reflow Soldering

回流焊温度曲线 Reflow Soldering Temperature Profile

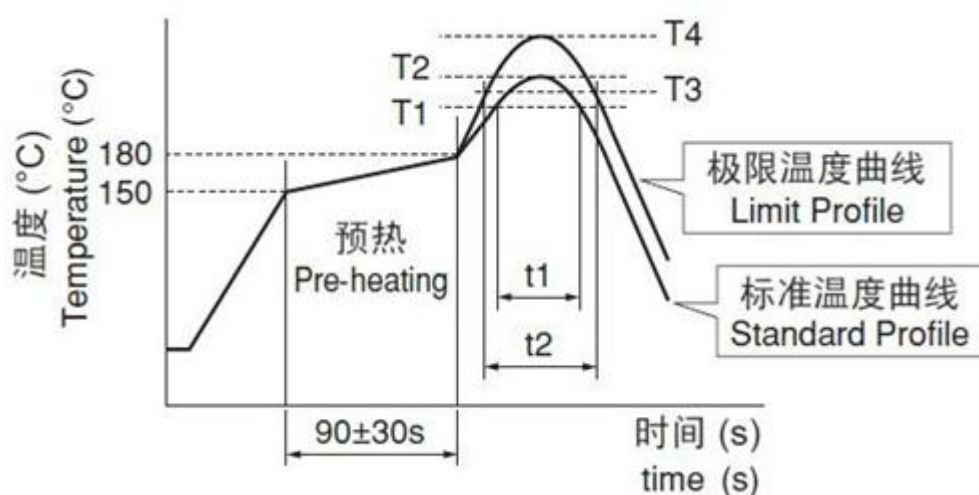

回流焊要求 Reflow Soldering Requirements

标准温度曲线Standard Profile				极限温度曲线Limit Profile			
加热Heating		峰值温度 Peak Temp. (T2)	回流焊 次Cycle Of Reflow	加热Heating		峰值温度 Peak Temp. (T4)	回流焊次数 Cycle Of Reflow
加热 Temp. (T1)	时间 Time (t1)			温度 Temp. (T3)	时间 Time (t2)		
220°C	30~60s	245±3°C	≤2	230°C	≤60s	260°C/10s	1

(2)、波峰焊 Flow Soldering

波峰焊温度曲线 Flow Soldering Temperature Profile

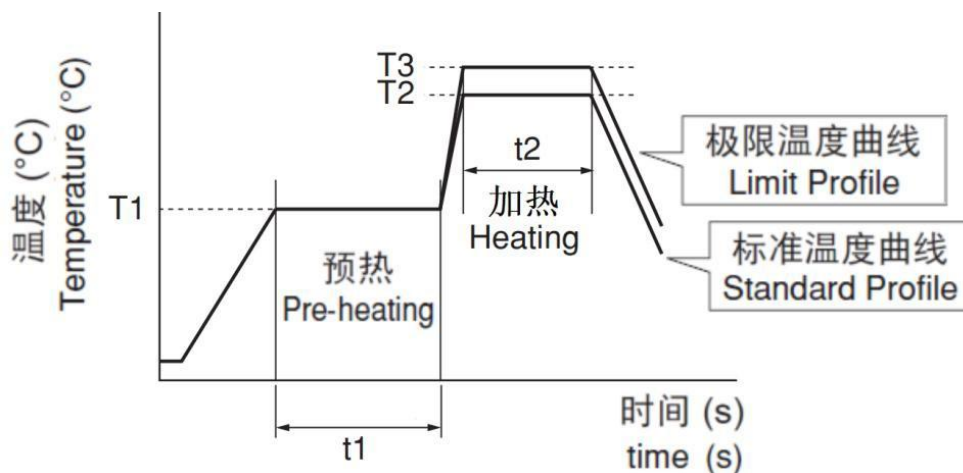

波峰焊要求 Flow Soldering Requirements

预热 Pre-heating		标准温度曲线 Standard Profile			极限温度曲线 Limit Profile		
		加热 Heating		波峰次数 Cycle Of Flow	加热		波峰次数 Cycle Of Flow
温度 Temp (T1)	时间 Time (t1)	温度 Temp (t2)	时间 Time (t2)		温度 Temp. (T3)	时间 Time (t2)	
150°C	≥60s	250°C	4s ~ 6s	≤2	265±3°C	≤5s	1

6、其他

- ◆ 本产品为无铅，请采用无铅环境作业
- ◆ Other: Our company's products are lead-free, please operate in a lead-free environment
- ◆ 由于页面限制，更多资料请联系我司
- ◆ Due to page limitations, please contact our company for more information
- ◆ 在过载电流等不正常条件下，本电感产品无自我保护功能。
- ◆ Under abnormal conditions such as overload current, this inductor product has no self-protection function.