

## 1、产品概要 / Outline

- ◆ 高饱和电流极低阻值
- ◆ 具有两个相同绕组的耦合电感器
- ◆ 工作温度：-50°C+150°C
- ◆ 适用于汽车、军工、人工智能、航空航天等高可靠性的要求行业
- ◆ 广泛应用高功率开关稳压器、1:1 反激式转换器、Buck、Boost、Sepic 和 Cuk 转换器。



## 2、外观尺寸/ Appearance size 单位:mm

### Boundary dimension:

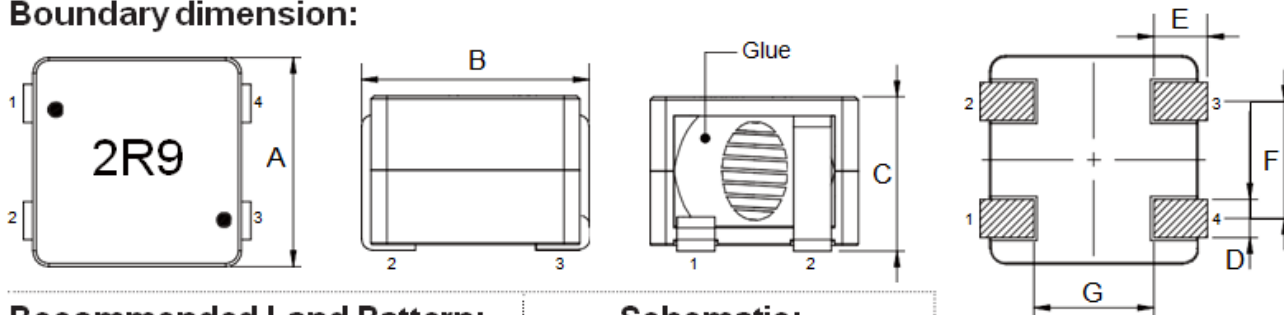

### Recommended Land Pattern:

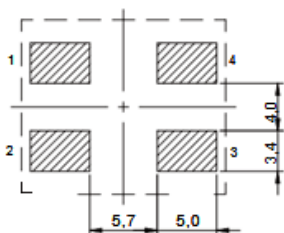

### Schematic:

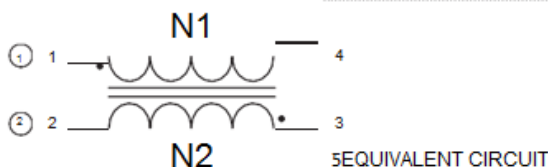

A	B	C	D	E	F	G
18.5±0.3	21.0Max	13.5Max	3.0Ref	3.0Ref	10.7Ref	7.7Ref

## 3、电气特性/Electrical characteristics

型号	L(OA)	DCR(mΩ)Max	Irms (Typ)	Isat (Typ)
SICM0713-6R8M	6.8	6.1	13.5	26
SICM0713-8R2M	8.2	8.4	13	24
SICM0713-100M	10	11	11.5	22

### 注释

- ◆ K 表示电感值的公差为±10%，M 表示电感值的公差为±20%
- ◆ K said inductance tolerance is ±10%, M said inductance tolerance is ± 20%
- ◆ 所有数据基于环境温度 25°C条件下测试
- ◆ All data is based on testing at an ambient temperature of 25 °C
- ◆ 测试条件：100KHz/1.0V
- ◆ 本页面未能录入全部或最新的数据，请您在订购前向本公司咨询精准参数及样品。

- ◆ We were unable to input all or the latest data on this page. Please consult our company for accurate parameters and samples before placing an order.

## 4 包装规格/ Packaging specifications 单位/mm

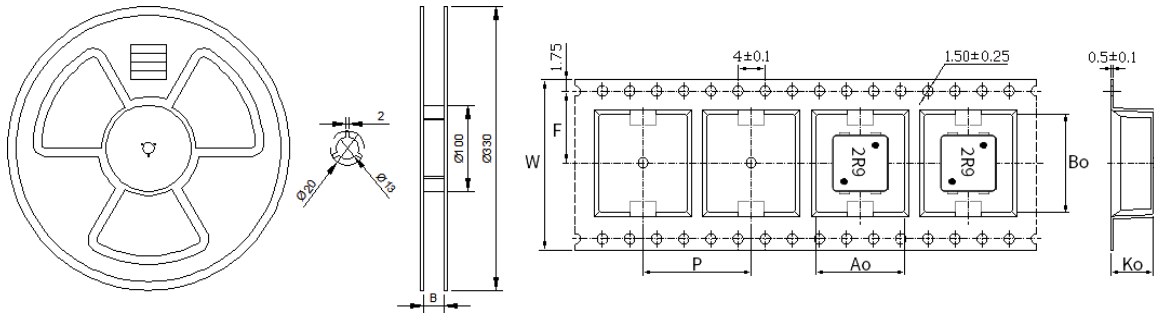

型号	A(Pcs/Reel)	B	W	P	Ao	Bo	Ko
SICM0510	300	32.5 ± 0.5	32	20	13.8 ± 0.15	15.8 ± 0.15	10.9 ± 0.1
SICM0512	200	32.5 ± 0.5	32	24	13.8 ± 0.15	15.8 ± 0.15	12.2 ± 0.1
SICM0713	150	44.5 ± 0.5	44	32	18.80Typ.	20.8Typ.	13.2Typ.

## 5、焊接/ welding

### • 焊接原材料 Soldering Materials

(a) 焊料 :推荐使用 96.5Sn/3.0Ag/0.5Cu 焊料 ,或者采用 Sn 含量不超过 97%的锡合金焊料。 Solder: It is recommended to use 96.5Sn/3.0Ag/0.5Cu solder, or use Tin alloy solder with a Tin content not exceeding 97%.

(b) 助焊剂 :推荐使用松香类助焊剂, 请勿使用强酸性助焊剂 (含氯量超过 0.2wt % ) , 并且请勿使用水溶性助焊剂。

Flux: It is recommended to use rosin-based flux. Acidic flux (with chlorine content exceeding 0.2wt %) and water-soluble flux are forbidden.

### • 焊接温度及要求 Soldering Temperature & Requirements

回流焊温度曲线 Reflow Soldering Temperature Profile

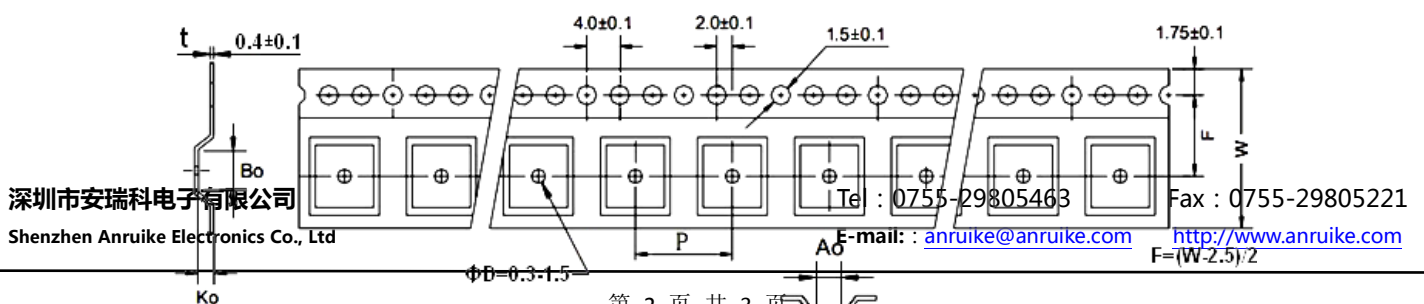

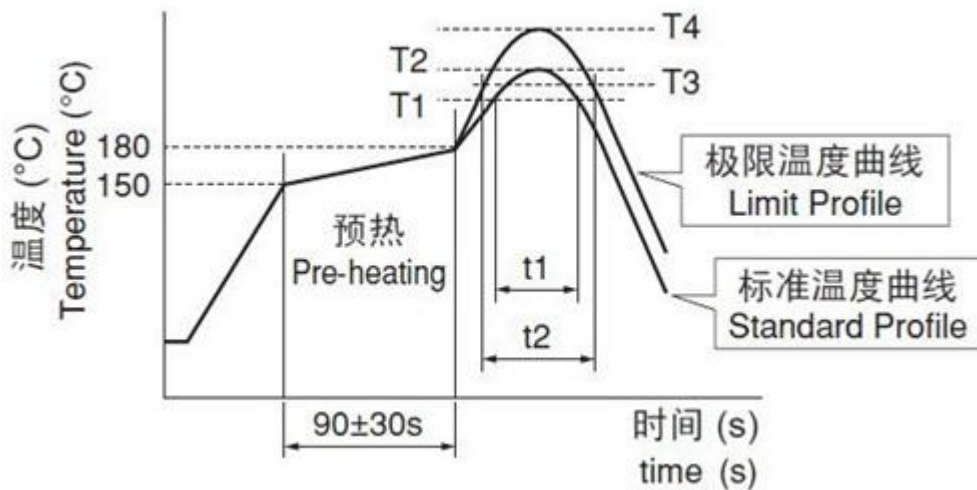

回流焊要求 Reflow Soldering Requirements

标准温度曲线Standard Profile				极限温度曲线Limit Profile			
加热Heating		峰值温度 Peak Temp. ( T2 )	回流焊 次Cycle Of Reflow	加热Heating		峰值温度 Peak Temp. ( T4 )	回流焊次数 Cycle Of Reflow
加热 Temp. ( T1 )	时间 Ti me ( t1 )			温度 Temp. ( T3 )	时间 Time ( t2 )		
220°C	30~60s	245±3°C	≤2	230°C	≤60s	260°C/10s	1

6、其他

- ◆ 本产品为无铅，请采用无铅环境作业
- ◆ Other: Our company's products are lead-free, please operate in a lead-free environment
- ◆ 由于页面限制，更多资料请联系我司
- ◆ Due to page limitations, please contact our company for more information
- ◆ 在过载电流等不正常条件下，本电感产品无自我保护功能。
- ◆ Under abnormal conditions such as overload current, this inductor product has no self-protection function.